

**W** Wymiary montażowe i gabarytowe

**B5**

Wielkość mech.	B5							B5R (zmniejszony)						D	E	F	G	AC	HD	L	KK	SS	XX	TBS
	M	N	P	T	S	R	M	N	P	T	S	R												
56	98	80	120	3,0	7	0	-	-	-	-	-	-	9	20	3	7,2	120	100	195	M16	M3	8	14	
63	115	95	140	3,0	10	0	-	-	-	-	-	-	11	23	4	8,5	130	110	215	M20	M4	10	14	
71	*	130	110	160	3,5	10	0	115	95	140	3,0	10	0	14	30	5	11	145	117	240	M20	M5	12	20
80		165	130	200	3,5	12	0	130	110	160	3,5	10	0	19	40	6	15,5	165	137	290	M20	M6	16	27
90	S																			310				
	L1	165	130	200	3,5	12	0	130	110	160	3,5	12	0	24	50	8	20	185	145	335	M20	M8	20	30
	L2																			365				
100	L*	215	180	250	4,0	15	0	165	130	200	3,5	12	0	28	60	8	24	205	152	368	M20	M10	22	26
112		215	180	250	4,0	15	0	165	130	200	3,5	12	0	28	60	8	24	230	180	395	M20	M10	22	32
132	S																			436				
	M	265	230	300	4,0	15	0	215	180	250	4	15	0	38	80	10	33	270	193	474	M25	M12	28	38
	L																			500				
160	M	300	250	350	5,0	19	0	-	-	-	-	-	-	42	110	12	37	320	230	640	M32	M16	35	64
	L																							

\* dotyczy silników o mocach progresywnych

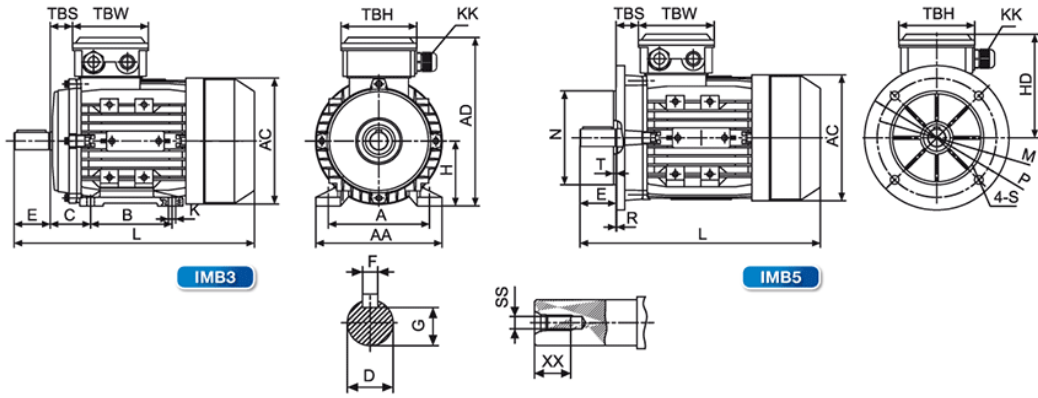

**W** Wymiary montażowe i gabarytowe

**B3**

Wielkość mech.	H	A	B	C	D	E	F	G	K	AA	AD	AC	L	KK	SS	XX	TBS	TBW	TBH	
56	56	90	71	36	9	20	3	7,2	5,8	110	156	120	195	M16	M3	8	14	88	88	
63	63	100	80	40	11	23	4	8,5	7	120	173	130	215	M20	M4	10	14	94	94	
71	71	112	90	45	14	30	5	11	7	132	188	145	240	M20	M15	12	20	94	94	
80	80	125	100	50	19	40	6	15,5	10	160	217	165	254	M20	M6	16	27	105	105	
90	S	90	100	56	24	50	8	20	10	175	235	185	310	M20	M8	20	30	105	105	
	L1		125										335							
	L2		125										365							
100	L	100	160	140	63	28	60	8	24	196	252	205	368	M20	M10	22	26	105	105	
													386							
112	L	112	190	140	70	28	60	8	24	220	292	230	395	M25	M10	22	32	112	119	
													436							
													474							
132	S	132	216	140	89	38	80	10	33	12	252	325	270	M25	M12	22	38	112	119	
	M			178																474
	L			178																500
160	L	160	254	210	108	42	110	12	37	15	290	390	320	640	M32	M16	35	64	143	146
				254																

\* dotyczy silników o mocach progresywnych

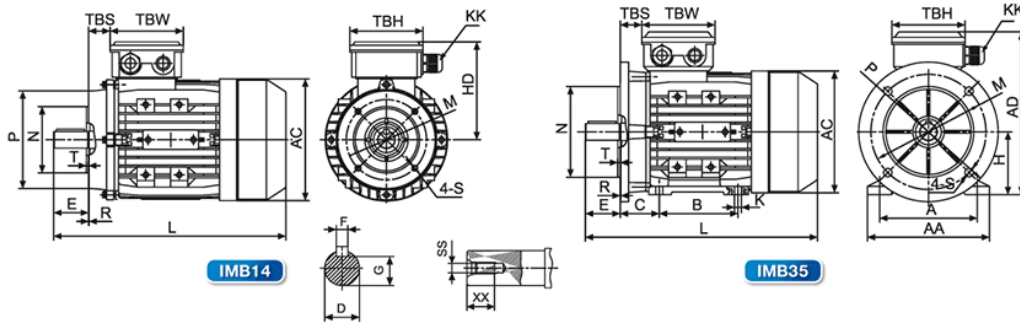

**W** Wymiary montażowe i gabarytowe

**B14**

Wielkość mech.	B14						B14B						D	E	F	G	AC	HD	L	KK	SS	XX	TBS	
	M	N	P	T	S	R	M	N	P	T	S	R												
56	65	50	80	2,5	M5	0	-	-	-	-	-	9	20	3	7,2	120	100	195	M16	M3	8	14		
63	75	60	90	2,5	M5	0	100	80	120	3,0	M6	0	11	23	4	8,5	130	110	215	M20	M4	10	14	
71	85	70	105	2,5	M6	0	115	95	140	3,0	M8	0	14	30	5	11	145	117	240	M20	M5	12	20	
80	100	80	120	3,0	M6	0	130	110	160	3,5	M8	0	19	40	6	15,5	165	137	254	M20	M6	16	27	
90	S	115	95	140	3,0	M8	0	130	110	160	3,5	M8	0	24	50	8	20	185	145	310	M20	M8	20	30
	L1																			335				
	L2																			365				
100	L	130	110	160	3,5	M8	0	165	130	200	3,5	M10	0	28	60	8	24	205	152	368	M20	M10	22	26
112		130	110	160	3,5	M8	0	165	130	200	3,5	M10	0	28	60	8	24	230	180	386	M25	M10	22	32
132	S	165	130	200	3,5	M10	0	215	180	250	4,0	M12	0	38	80	10	33	270	193	436	M25	M12	28	38

\* dotyczy silników o mocach progresywnych

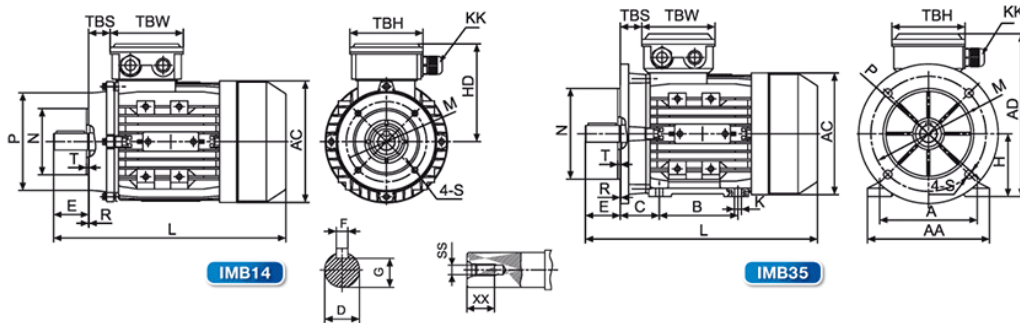

**W** Wymiary montażowe i gabarytowe

**B35**

Wielkość mech.	H	B35						B35R (zmniejszony)						A	B	C	D	E	F	
		M	N	P	T	S	R	M	N	P	T	S	R							
56	56	98	80	120	3,0	7	0	-	-	-	-	-	-	90	71	36	9	20	3	
63	63	115	95	140	3,0	10	0	-	-	-	-	-	-	100	80	40	11	23	4	
71	71	130	110	160	3,5	10	0	115	95	140	3,0	10	0	112	90	45	14	30	5	
80	80	165	130	200	3,5	12	0	130	110	160	3,5	10	0	125	100	50	19	40	6	
90	S	90	165	130	200	3,5	12	0	130	110	160	3,5	12	0	140	100	56	24	50	8
	L1															125				
	L2																			
100	L	100	215	180	250	4,0	15	0	165	130	200	3,5	12	0	160	140	63	28	60	8
112		112	215	180	250	4,0	15	0	165	130	200	3,5	12	0	190	140	70	28	60	8
132	S	132	265	230	300	4,0	15	0	215	180	250	4,0	15	0	216	140	89	38	80	10
	M															178				
	L																			
160	M	160	300	250	350	5,0	19	0	-	-	-	-	-	-	254	210	108	42	110	12

\* dotyczy silników o mocach progresywnych